

未注公差/General tolerances(mm)											0.1/10		
0	>3	>6	>10	>18	>30	>50	>80	>120	>180	>250		>315	>400
~3	~6	~10	~18	~30	~50	~80	~120	~180	~250	~315	~400	~500	
±0.12	±0.18	±0.22	±0.26	±0.31	±0.37	±0.57	±0.80	±0.93	±1.05	±1.15	±1.60	±2.20	±2.50

A

B

C

D

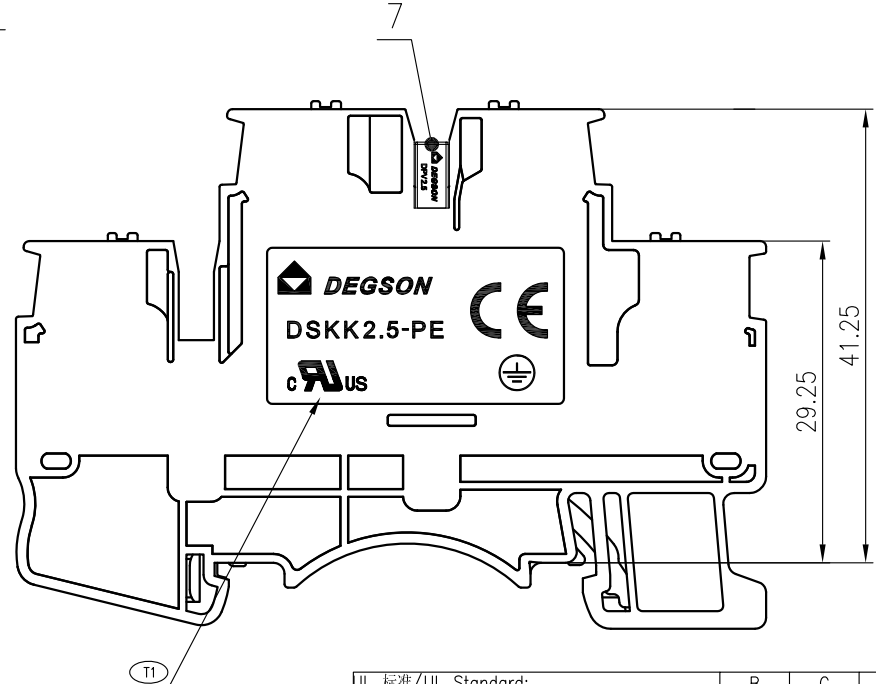
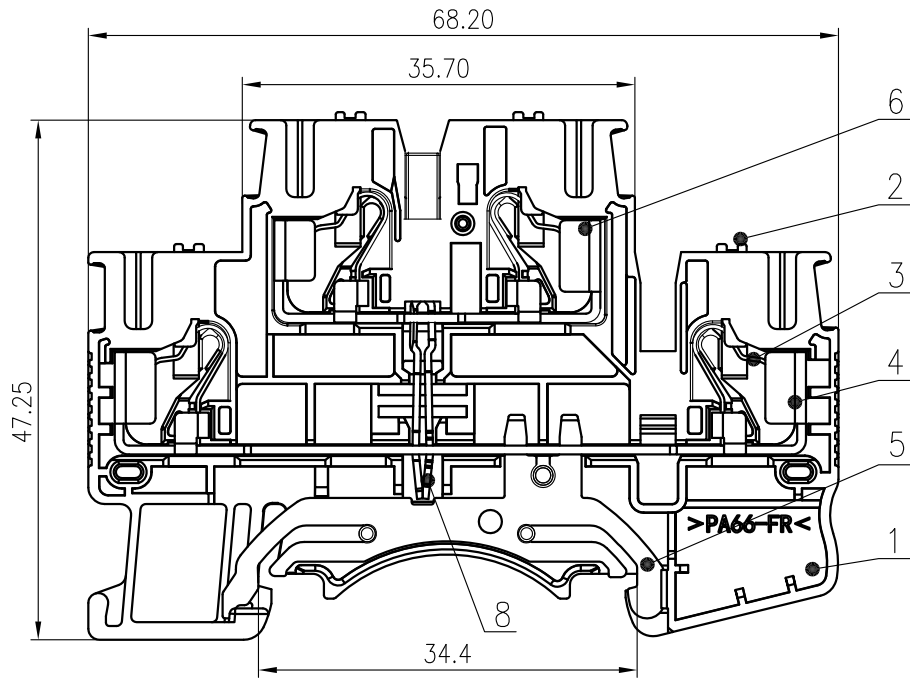

Please refer to the 3D model, for these unmarked dimensions.

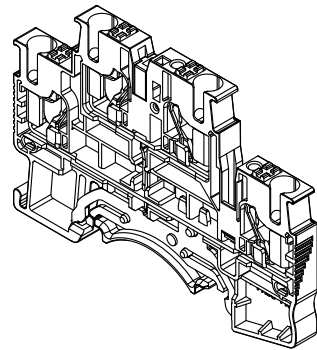

ITEM	NAME OF PART	MATERIAL	NOTES
8	Current carrier 3	Copper	Sn Plated
7	Housing 2	PA66	UL94 V-0
6	Current carrier 2	Copper	Sn Plated
5	Grounding	Copper alloy	Sn Plated
4	Current carrier 1	Copper	Sn Plated
3	Spring	Stainless steel	/
2	Button	PA66-GF	UL94 V-0
1	Housing 1	PA66	UL94 V-0

REV	ECN	DESCRIPTION	DRFT	DATE
T1	20-0175	Add UL certification label	Chen K	2020.05.26

UL 标准/UL Standard:	B	C	D
额定电压/电流/Rated Voltage(V)/Current(A)	/	/	/
IEC 标准/IEC Standard:			
过压类别/Overvoltage Category/污染等级/Pollution Degree	III/3	/	/
额定电压/电流/Rated Voltage(V)/Current(A)	/	/	/
额定脉冲电压(KV)/Rate Impulse Voltage(KV)	6.0	/	/
线径范围(硬线和软线)/Wire Range(rigid and flexible)(mm <sup>2</sup> /AWG)	0.2~2.5&4(S0L)/26~12		
间距/Pitch(mm)	5.20		
剥线长度/Stripping length(mm)	11~12		
使用温度范围/Operating temperature(°C)	-40~+105		
符合RoHS环保要求/Conform to RoHS	Yes		

MATERIAL: /	SURFACE: /		
MAT NO.: /	宁波高松电子有限公司 NINGBO DEGSON ELECTRICAL CO., LTD		
STATUS: /			
APPD: LiGL 2020.05.26	NAME: DSKK2.5-PE-01P-1C-00A(H)		
CHKD: Mao J 2020.05.26	DRAWING NO.: DSKK2.5-PE-C01		
DRFT: ChenK 2019.11.13	REV: T1		SHEET: 1/1
SIZE: A4	TYPE: CUSTOMER DRAWING	SCALE: 1:1	